

DOMESTIC TANKLESS GAS WATER HEATER

USER'S MANUAL

EZ Ultra

Read the installation instructions before installing the appliance.

Read the user's instructions before powering on the appliance.

DIRECT VENT CONCENTRIC EXHAUST MODEL



ISO9001 Certified

NOTICE: For your safety and the safety of others, this heater cannot be connected to an existing natural draft exhaust. Only the sealed-joint concentric intake/exhaust components made specifically for this heater can be used. There are no compromises, do not attempt to modify or substitute the exhaust/intake components of this heater! Multiple advanced redundant electrical safety devices are integrated into the electronics of this heater, they cannot be disconnected or bypassed and they are designed to detect any and all modifications and incorrect connections. These devices will prevent the heater from turning on. This heater will not run without the exhaust/intake pipe being connected.

PLEASE:

Do not proceed with the installation of this heater until you are familiar with the concept of concentric intake/exhaust direct vent technology. This exhaust system is actually two pipes in one. Most manufacturers have switched to this technology for many reasons. Maximum efficiency and safety are two primary reasons. As this technology is relatively new, it is not uncommon for users to not understand the concepts. If you are replacing an existing tank type heater, there is no possible way to use the old exhaust pipes. It will not work, do not try! With “Direct Vent” heaters made by any manufacturer, the intake air is drawn into the heater from outdoors via one chamber or pipe, the exhaust exits via a second chamber or pipe. With the EZ ULTRA model, the intake combustion air comes from outside via the outer concentric chamber of our dual chamber pipe and the exhaust exits through the inner part of the pipe.

If you are uncertain of what this technology means to you and how it saves you energy, please read this manual thoroughly and review the information and videos on our website at these links:

Technical information: <http://www.eztankless.com/ezultraexplained.html>

Videos: <http://www.eztankless.com/videosandphotos.html>

Thank you for your purchase and putting your trust in our company.

We are here to serve you, find us on the web at: <http://www.eztankless.com/>



PLEASE COMPLETELY READ THIS MANUAL

Inside you will find many helpful hints on how to use and maintain your water heater properly. A little preventive care on your part can save you time and money over the life of your water heater. You'll find many answers to common problems in the Troubleshooting Guide. If you review the chart of *Troubleshooting Tips* first, you may not need to call for service.

KEY WORDS USED IN THIS MANUAL

All safety messages will use either the word "DANGER", "WARNING", "CAUTION" or "NOTICE".

These words mean:

DANGER - An imminently hazardous situation that will result in death or serious injury.

WARNING - A potentially hazardous situation that could result in death or serious injury and/or damage to property.

CAUTION - A potentially hazardous situation that may result in minor or moderate injury.

NOTICE - Attention is called to observe a specified procedure or maintain a specific condition.



FOR YOUR RECORDS

Write the model and serial numbers here:

#

#

You can find them on a label on the appliance.

Staple sales slip or cancelled check here. **Proof of the original purchase date is needed to obtain service under the warranty.**

READ AND FOLLOW THIS SAFETY INFORMATION CAREFULLY.

SAVE THESE INSTRUCTIONS

DANGER!

PROPERLY INSTALL AND VENT THIS WATER HEATER...

Failure to properly install and properly vent the water heater to the outdoors as outlined in the Venting Section of the Installation Instructions in this manual can result in unsafe operation of the water heater. To avoid the risk of fire, explosion or asphyxiation from carbon monoxide, never operate this water heater unless it is properly vented and has an adequate air supply for proper operation.

Be sure to inspect the vent terminal, the air intake, and the coaxial vent system on the water heater for proper installation at initial start-up; and at least annually thereafter. Refer to the Care and Cleaning section of this manual for more information regarding vent system inspection.

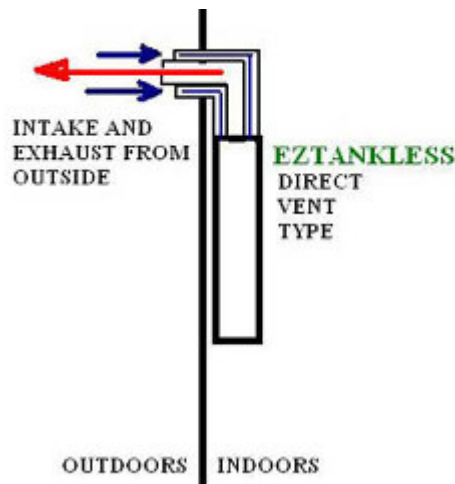

WARNING!

Gasoline, as well as other flammable materials and liquids (adhesives, solvents, paint thinners etc.), and the vapors they produce are extremely dangerous. DO NOT handle, use or store gasoline or other flammable or combustible materials anywhere near or in the vicinity of a water heater or any other appliance. Be sure to read and follow the labels on the water heater, as well as the warnings printed in this manual. Failure to do so can result in property damage, bodily injury or death.

▲ DANGER

▲ Vapors from flammable liquids will explode and catch fire causing death or severe burns.
Do not use or store flammable products such as gasoline, solvents or adhesives in the same room or area near the water heater.

Keep flammable products:

1. far away from heater,
2. in approved containers,
3. tightly closed and
4. out of children's reach.

Water heater has a main burner flame.
The main burner flame:

1. which can come on at any time and
2. will ignite flammable vapors.

Vapors:

1. cannot be seen,
2. are heavier than air,
3. go a long way on the floor and
4. can be carried from other rooms to the main burner flame by air currents.

Installation:
Do not install water heater where flammable products will be stored or used unless the main burner flame is at least 18" above the floor. This will reduce, but not eliminate, the risk of vapors being ignited by the main burner flame.

Read and follow water heater warnings and instructions. If owners manual is missing, contact the retailer or manufacturer.

▲ DANGER!

WATER TEMPERATURE SETTING

Safety and energy conservation are factors to be considered when selecting the water temperature setting of a water heater's remote control. Water temperatures above 125°F (52°C) can cause severe burns or death from scalding. Be sure to read and follow the warnings outlined on the label pictured below.

Time/Temperature Relationship in Scalds

Water Temperature	Time To Produce a Serious Burn
120°F (49°C)	More than 5 minutes
125°F (52°C)	1½ to 2 minutes
130°F (54°C)	About 30 seconds
135°F (57°C)	About 10 seconds
140°F (60°C)	Less than 5 seconds
145°F (63°C)	Less than 3 seconds
150°F (66°C)	About 1½ seconds
155°F (68°C)	About 1 second

Table courtesy of Shriners Burn Institute

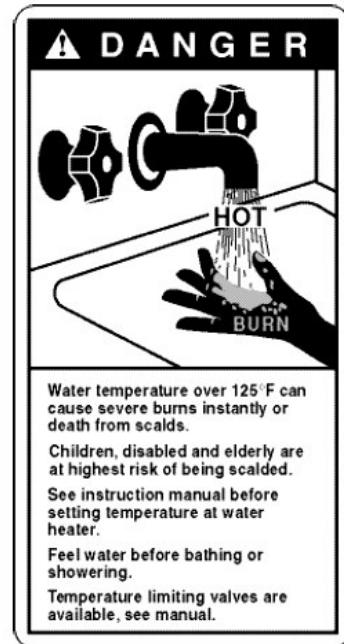

▲ WARNING There is a hot water scald potential if the thermostat is set to high.

▲ WARNING CHECK WATER TEMPERATURE BEFORE ENTERING SHOWER OR BATH.

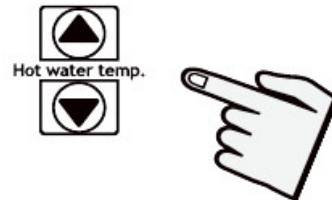

DANGER!

NATURAL GAS AND LIQUEFIED PETROLEUM MODELS

Both LP and natural gas have an odorant added to aid in detecting a gas leak. Some people may not physically be able to smell or recognize this odorant. If you are unsure or unfamiliar with the smell of LP or natural gas, ask the gas supplier. Other conditions, such as “odorant fade”, which causes the odorant to diminish in intensity, can also hide or camouflage a gas leak.

- Water heaters utilizing LP gas are different from natural gas models. A natural gas water heater will not function safely on LP gas and vice versa.
- No attempt should ever be made to convert the water heater from natural gas to LP gas. To avoid possible equipment damage, personal injury or fire, do not connect the water heater to a fuel type not in accordance with the unit data plate; propane for propane units and natural gas for natural gas units. These units are not certified for any other fuel type.
- LP appliances should not be installed below grade (for example, in a basement) if such installation is prohibited by federal, state and/or local laws, rules, regulations or customs.
- Propane or LP gas must be used with great caution. It is heavier than air and will collect first in lower areas, making it hard to detect at nose level.
- Before attempting to light the water heater, make sure to look and smell for gas leaks. Use a soapy solution to check all gas fittings and connections. Bubbling at a connection indicates a leak that must be corrected. When smelling to detect a gas leak, be sure to sniff near the floor also.
- Gas detectors are recommended in LP and natural gas applications and their installation should be in accordance with the detector manufacturer’s recommendations and/or local laws, rules, regulations or customs.
- It is recommended that more than one method, such as soapy solution, gas detectors, etc., be used to detect leaks in gas applications.

Notice: If a gas leak is present or suspected:

- ***Do not*** attempt to find the cause yourself.
- ***Do not*** try to light any appliance.
- ***Do not*** touch any electrical switch.
- ***Do not*** use any phone in your building.
- Leave the building immediately and make sure your family and pets leave also.
- Leave the doors open for ventilation and contact the gas supplier, a qualified service agency or the fire department.
- Stay away from the building until the service call has been made, the leak is corrected and a qualified agency has determined the area to be safe.

SAFETY PRECAUTIONS

Have the installer show you the location of the gas shut-off valve and how to shut it off if necessary. Turn off the manual shut-off valve if the water heater has been subjected to overheating, fire, flood, physical damage or if the gas supply fails to shut off.

Read this manual entirely before installing or operating the water heater.

Use this appliance only for its intended purpose as described in this Instruction Manual.

Be sure your appliance is properly installed in accordance with local codes and the provided installation instructions.

Do not attempt to repair or replace any part of your water heater unless it is specifically recommended in this manual. All other servicing should be referred to a qualified technician.

NOTICE: The water heater should not be installed near an air supply containing halogenated hydrocarbons.

Corrosive Atmospheres

The air in beauty shops, dry cleaning establishments, photo processing labs, and storage areas for liquid and powdered bleaches or swimming pool chemicals often contains such halogenated hydrocarbons.

An air supply containing halogenated hydrocarbons may be safe to breathe, but when it passes through a gas flame, corrosive elements are released that will shorten the life of any gas burning appliance.

Propellants from common spray cans or gas leaks from A/C and refrigeration equipment are highly corrosive after passing through a flame.

The water heater warranty is voided when failure of the heater is due to operation in a corrosive atmosphere.

WARNING

Always turn off the electrical power supply, the manual gas valve and the manual water control valve whenever servicing the unit.

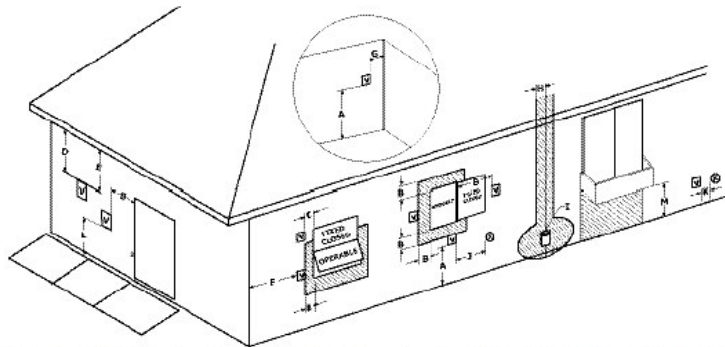

V VENT TERMINAL
 AIR SUPPLY INLET
 AREA WHERE TERMINAL IS NOT PERMITTED

Horizontal Vent Terminal Location

The following information should be used for determining the proper location of the vent terminal for direct vent tankless water heaters.

	Canadian Installations ¹	US Installations ²
A= Clearance above grade, veranda, porch, deck or balcony.	12 inches (30 cm) above anticipated snow level.	12 inches (30 cm) above anticipated snow level.
B= Clearance to window or door that may be opened.	6 inches (15 cm) for appliances ≤ 10,000 Btuh (3 kW), 12 inches (30 cm) for appliances > 10,000 Btuh (3kW) and ≤ 100,000 Btuh (30kW), 36 inches (91 cm) for appliances > 100,000 Btuh (30kW).	6 inches (15 cm) for appliances ≤ 10,000 Btuh (3 kW), 9 inches (23 cm) for appliances > 10,000 Btuh (3kW) and ≤ 50,000 Btuh (15kW), 12 inches (30 cm) for appliances > 50,000 Btuh (15kW).
C= Clearance to permanently closed window.	*	*
D= Vertical Clearance to ventilated soffit located above the terminal within a horizontal distance of 2 feet (61 cm) from the center line of the terminal.	*	*
E= Clearance to unventilated soffit.	*	*
F= Clearance to outside corner.	*	*
G= Clearance to corner.	*	*
H = Clearance to each side of center line extended meter/regulator assembly, above	3 feet (91 cm) within a height 15 feet (4.57 m) above the meter/regulator assembly.	*
I = Clearance to service regulator coaxial vent outlet	3 feet (91 cm)	*
J = Clearance to nonmechanical air supply inlet to the combustion air inlet to any building or other appliance.	6 inches (15 cm) for appliances ≤ 10,000 Btuh (3 kW), 12 inches (30 cm) for appliances > 10,000 Btuh (3kW) and ≤ 100,000 Btuh (30kW), 36 inches (91 cm) for appliances > 100,000 Btuh (30kW).	6 inches (15 cm) for appliances ≤ 10,000 Btuh (3 kW), 9 inches (23 cm) for appliances > 10,000 Btuh (3kW) and ≤ 50,000 Btuh (15kW), 12 inches (30 cm) for appliances > 50,000 Btuh (15kW).
K = Clearance to mechanical air supply inlet.	6 feet (1.83 m)	3 feet (91 cm) above if within 10 feet (3 m) horizontally.
L = Clearance above paved sidewalk or paved driveway located on public property.	Not Allowed	Not Allowed
M = Clearance under veranda, porch, deck or balcony.	Not Allowed	Not Allowed

1 In accordance with current CAN/CGA-B149 Installation Codes.

2 In accordance with current ANSI Z223.1/ NFPA 54 National Fuel Gas Code.

* If clearances are not specified, then follow local installation codes and the requirement of the gas supplier.

Indoor Water Heater

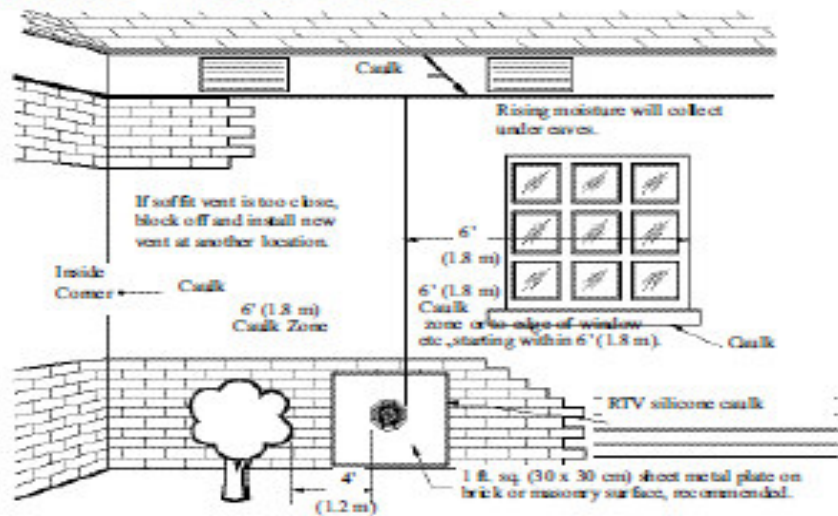

⚠ WARNING: Moisture in the flue gas will condense as it leaves the vent terminal. In cold weather this condensate can freeze on the exterior wall, under the eaves and on surrounding objects. Some discoloration to the exterior of the building is to be expected. However, improper location or installation can result in severe damage to the structure or exterior finish of the building.

⚠ WARNING: For multiple unit installation, a minimum distance between vent terminations must be maintained to prevent recirculation of vent gases. Maintain a center-to-center distance between vent terminations of 19 inches (48 cm) for two unit installation. Maintain a center-to-center distance between vent terminations of 21 inches (53 cm) for three or more unit installation.

Venting System Inspection

The venting system of a direct vent water heater should be inspected annually to ensure all of the vent sections are secure and air-tight.

It is recommended that qualified service personnel familiar with Category III venting inspect the venting system.

Check vent connection joint sections with a solution of soapy water to assure air-tightness while the unit is operating.

Bubbles around a joint connection indicates a seal leak.

DO NOT operate the unit if vent system shows signs of leaking exhaust.

Check to make sure that the air intake opening and vent outlet on the termination has not been blocked or contain debris.

IMPORTANT: Do not apply heat to the HOT or COLD water connections. If sweat connections are used, sweat tubing to adapter before fitting adapter to the water connections on heater. Any heat applied to the water supply fittings will permanently damage the internal components of the water heater.

Water Supply Connections

Plumbing should be carried out by a qualified plumber in accordance with local codes.

Use approved plumbing materials only.

To conserve energy and to prevent freezing, insulate both cold and hot water supply lines. DO NOT cover the drain or pressure relief valve.

To ensure proper operation of the water heater, the following water pressure guidelines should be followed:

⚠ CAUTION: This water heater must only be used with the following water supply system conditions:

- With clean, potable water free of corrosive chemicals, sand, dirt or other contaminants.
- With inlet water temperatures above 32°F (0°C), but not exceeding 120°F (49°C).
- Free of lime and scale deposits.
- DO NOT reverse the hot and cold water connections. The water heater will not operate.

Vacation and Extended Shut-Down

If the water heater is to remain idle for an extended period of time, the power and water to the appliance should be turned off.

The water heater and piping should be drained if they might be subjected to freezing temperatures.

After a long shut-down period, the water heater's operation and controls should be checked by qualified service personnel.

INSTALLATION:

Contact your local gas dealer or utility company specialist for a qualified engineer to evaluate your plans and always use a qualified technician to install the gas water heater.

LOCATION FOR INSTALLATION:

The flue of this gas water heater should be installed through an external wall; the heater can't be installed outdoors

WARNING:

The Direct Vent Exhaust of this heater can't be connected to a common natural draft flue!

Please don't install the heater in places where special chemicals are used, like the laundry or factory etc., otherwise it may cause internal metal corrosion and shorten the life of the heater, or even cause it to function abnormally.

Try not to install the exhaust of the heater through the wall of a room with nearby open windows as the waste gasses may flow back into the building due to drafts and wind conditions. See above drawings, diagrams and rules for general rules of exhaust spacing in relation to openings, windows, soffits and doorways. Always check local and State code. This is why only trained professionals should install any gas-fired device.

The heater is 115V 60 cycles and must be plugged into a ground fault protected outlet as per code. The outlet should not be directly below the heater in case of water leakage.

Never install the heater above or directly against any other electrical or gas fired device.

INSTALLATION METHODS:

Drill holes on the wall affix as necessary. Use expansion bolts in the upper hole for a secure mounting. Do not mount the heater to flammable materials. See local and/or State code. Consult a professional at all times. In many locations, installation must pass the scrutiny of the local code inspector, if unsure of local rules and regulations; please be sure to verify the proper way in which to install this heater. This way you can avoid unnecessary or additional expenses.

The proper mounting height is suitable when the flame check window is in a location that can easily be seen with the eye.
(4 - 6ft above the ground)

No visible electrical wire or any electric appliance is permitted above the heater, the horizontal distance between the heater and any other electrical appliance should be more than 1.5 feet

NOTICE:

FOR YOUR SAFETY, PLEASE READ THIS MANUAL CAREFULLY AND FOLLOW ALL DIRECTIONS.

1) Follow all local codes, or in the absence of local codes, follow the most recent edition of the National Fuel Gas Code, ANSI Z223.1/NFPA 54 in the USA or the CAN/CSA B149.1 Natural Gas and Propane Installation Code in Canada.

2) Properly ground the unit in accordance with all local codes or in the absence of local codes, with the National Electrical Codes, ANSI/NFPA 70 in the USA or CSA standard C22.1 Canada Electrical Code Part 1 in Canada.

3) Carefully plan where you intend to install your Water Heater. Ensure that your heater will have enough combustible air and proper ventilation and locate your heater where water leakage will not do damage to surrounding areas. If there is a possibility of water damage, install a suitable drain pan under the unit which will not restrict combustible airflow.

Installer must install a Pressure relief valve. Pipe the pressure relief discharge to a drain or outside environment.

4) Check the rating plate for the correct gas type, gas pressure, water pressure and electrical rating. If this unit does not match your requirements, do not install.

5) If any problem should occur, turn off all hot water taps and turn off the gas. Then call a trained technician or the Gas Company or the manufacturer.

NOTE: The installer is responsible for the correct installation of your Water Heater.

Installation and service must be performed by a qualified installer (for example, a licensed plumber or gas fitter) otherwise the warranty by EZTANKLESS will be void.

6) Read the safety issues completely before installing the Water Heater.

7) This water heater is suitable for residential water (potable) heating **ONLY**.

DO NOT use this water heater for space heating, combination space heating/ domestic water heating, or commercial water heating applications.

8) The EZ ULTRA Water Heater is not suitable for use in pool or spa applications.

9) This unit is designed to be installed indoors using the proper vent piping to exhaust by-products of combustion to the outside environment. Contact your dealer or EZ

TANKLESS for proper vent kits. **DO NOT** run this unit without **OUR ORIGINAL EQUIPMENT** vent piping connected. Exhaust gasses must be expelled outside the home.

10) Maintain proper space around the unit for proper servicing and operation. Minimum clearances from combustible materials are listed below.

Top of Heater 6 inches

Back of Heater 1 inch

Front of Heater 6 inches

Sides of Heater 2 inches

Floor 12 inches

Vent/Air Intake 0 inches

Installing the water heater:

Typical Installation of Water Heater (Venting Required)

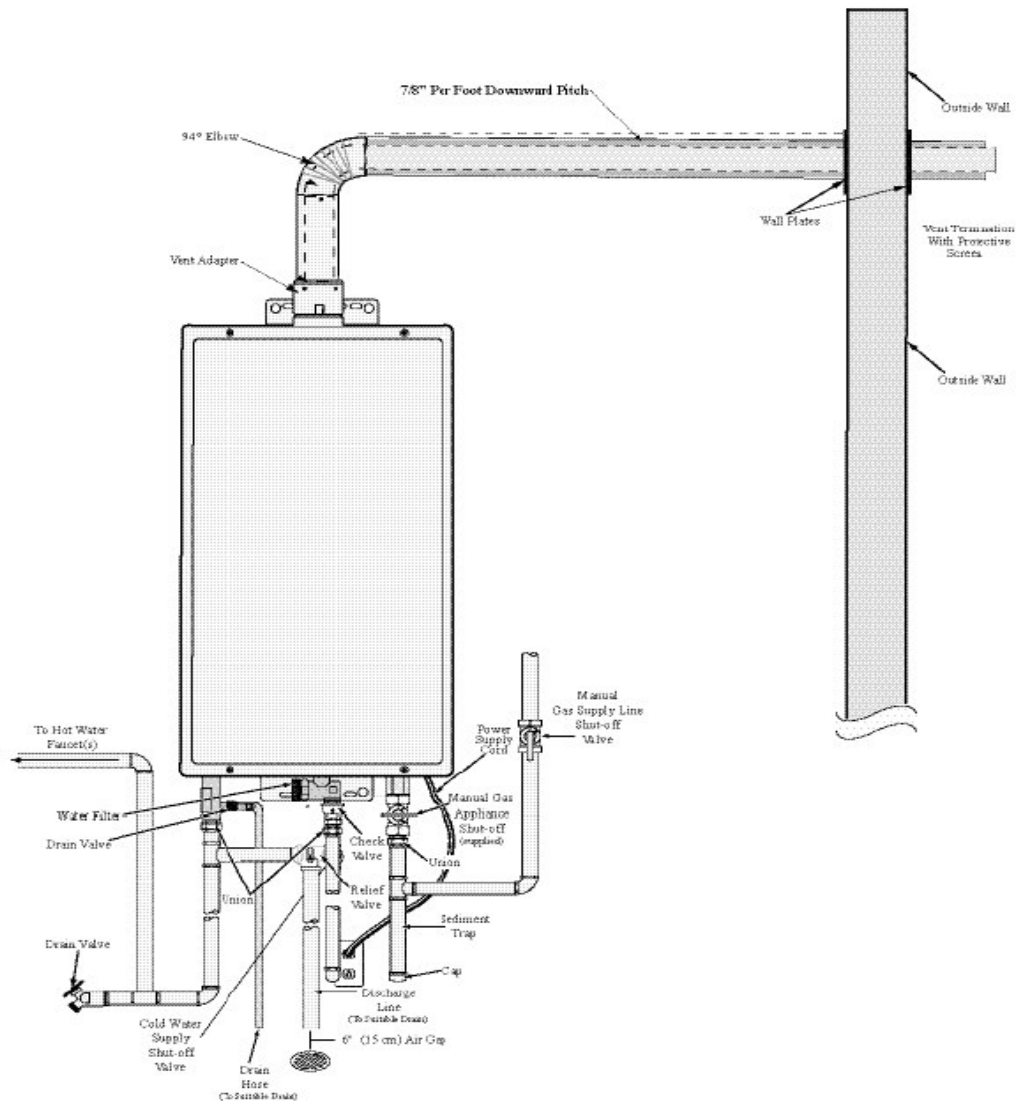

Model identification information

- EZ** Official EZ tankless water heater brand
- B** Referring to Forced Balanced Exhaust system
- 25** Rated heat input 25KW
- NG** Natural Gas (model for this gas type)
- LP** Liquid petroleum gas “propane” (model for this gas type)

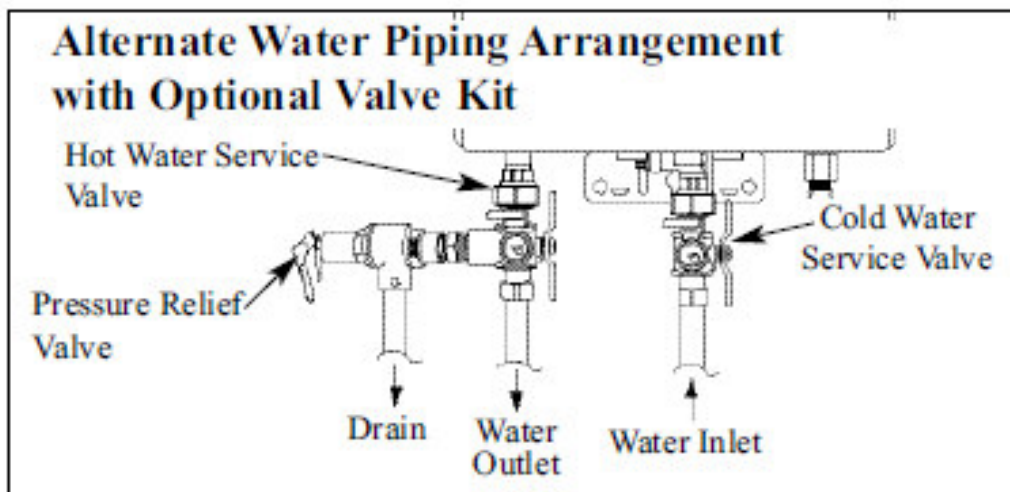

NOTICE: The National Fuel Gas Code (NFGC) and B149 mandates a manual gas shut-off valve: See NFGC/B149 for complete instructions. Local codes or plumbing authority requirements may vary from the instructions or diagrams provided and take precedent over these instructions.

DANGER:

When this heater is in use, there is obviously a combustion process which generates heat to make hot water. The combustion of almost all combustible materials and flammable gases of any kind typically consumes a large amount of oxygen and in turn this combustion process produces many different by-products in the smoke (exhaust) which include Carbon Monoxide. Regardless of how clean the combustion process is, there are always exhaust gasses that are emitted at some level. Breathing too much Carbon Monoxide will cause imminent danger or even death. Therefore, the users of this heater are requested to install and use this heater strictly according to the warnings set forth in this manual to avoid possible Carbon Monoxide intoxication. The manufacturer or its authorized distributors will not be held responsible for any danger resulting from the installation and operations not in accordance with this manual. Always install a Carbon Monoxide detector in the area of any gas fired appliances. In fact, this may be the law in your State or town and failure to do so is in violation of many state and local codes.

WARNING:

This product can only be used after an Official EZ Tankless Direct Vent Exhaust System is installed.

NOTICE:

This heater is not designed to be mounted in areas outdoors or unheated structures if temperatures can drop below freezing.

When the temperature of the room in which this heater is mounted drops below freezing the residual water must be drained from this unit.

WARNING:

FOR YOUR SAFETY, READ BEFORE OPERATING

If you do not follow these instructions exactly, a fire or explosion may result causing property damage, personal injury or loss of life.

A. This appliance does not have a pilot. It is equipped with a direct ignition device which automatically lights the burner. Do not try to light the burner by hand.

B. BEFORE OPERATING: Smell all around the appliance area for gas. Be sure to smell next to the floor because Some gas is heavier than air and will settle on the floor.

 **WARNING:** Never use an open flame to test for gas leaks, as property damage, personal injury, or death could result.

Leak Testing

The water heater and its gas connections must be leak tested at normal operating pressures before it is placed in operation.

 Turn on the gas shut-off valve(s) to the water heater.

 Use a soapy water solution to test for leaks at all connections and fittings. Bubbles indicate a gas leak that must be corrected.

The factory connections should also be leak tested after the water heater is placed in operation.

NOTE:

WHAT TO DO IF YOU SMELL GAS

- Do not try to light any appliance.
- Do not touch any electric switch; do not use any phone in your building.
- Immediately call your gas supplier from a neighbor's phone. Follow the gas supplier's instructions.
- If you cannot reach your gas supplier, call the fire department.

Use only your hand to operate control keypad. Never use tools. If the keypad doesn't work, do not try to repair it, call a qualified service technician. Force or attempted repair may result in a fire or explosion.

Do not use this appliance if any part has been under water. Immediately call a qualified service technician to inspect the appliance and to replace any part of the control system and any gas control which has been under water.

FEATURES:

This tankless water heater uses the Direct Vent Exhaust System. This is absolutely the safest and most economical ventilation method in use among tankless water heaters. This method uses a dual-chamber intake/exhaust pipe and a forced air system. This model is suitable for showering, using the sink, a clothes washing machine or even your dishwasher. This tankless water heater uses all of the safest and most efficient technologies available today, making it a leader in its class of tankless water heaters.

DIRECT VENT CONCEPT:

Since this product adopts the method of forced exhaust and fresh air supply for combustion, this air needed for combustion is completely from outdoors, and the waste gases produced by combustion are forcedly discharged to the outdoors, therefore, the air indoors won't be consumed and polluted. This removes some of the dangerous factors related to the potential of an insufficient oxygen supply and Carbon Monoxide poisoning. This model can be installed in the home with a horizontal exit directly to an outside wall.

EASE OF OPERATION:

Featuring fully automatic ignition that is controlled by a flow sensor, which is triggered by the movement of water when a faucet or water tap is opened.

CONVENIENT ADJUSTMENT:

Water volume and gas flow are regulated independently, allowing for a very accurate control of the desired pre-set water temperature.

ENERGY SAVINGS AND HIGH EFFICIENCY:

The burner and heat exchanger are designed by using an advanced combustion theory, incorporating features of high efficiency and clean and complete combustion performance.

LOW WATER PRESSURE IGNITION:

In order to meet the needs of well users and those living at high altitudes, we specially designed a low water pressure ignition for this product, it can work under 35 PSI water pressure.

COMPUTER CONTROL:

Computer controlled ignition and water flow sensor allow for maximum efficiency.

MULTIPLE REDUNDANT SAFETY PROTECTION SYSTEMS:

Multiple safety protection devices. For example, in case of a sudden flame out or lack of water supply or electrical power, the systems provide an instantaneous automatic shut-off.

ADVANCED DIGITAL CONSTANT TEMPERATURE TECHNOLOGY:

”Set it and forget it” technology. Set your EZ ULTRA tankless water heater to the desired temperature and the computer controlled system will keep the flowing water at a constant temperature, no matter the change in water flow.

(NOTE: Within the limits of the design and specified GPM capacity)

TOUCH CONTROL PANEL SETTINGS:

Design includes easy to operate LCD display of temperature settings, which can be adjusted using the simple “+” and “-“ buttons.

(NOTE: Normal bath water temperature is about 105 ° F just for your reference.)

NOTE:

This product’s safety features are lab tested. Please be careful and follow all State and Local regulations and codes when installing and using your tankless water heater.

NOTE:

WATER QUALITY

No manufacturer builds a tankless heater that can hold sediment and mineral deposits inside. Tank type heaters often have deep sediment loads that build up over years and accumulate in the bottom of the tank. By design, there is no place in a tankless heater for this accumulation of sediments and minerals. Over time, your tankless heater will become less and less efficient unless you address the issue of water quality. This must be done at the time of installation. Even though you may have city water, there may still be unacceptable levels of sediment and minerals that can harm your tankless heater in a short period of time. Consideration of care for your water heater must include evaluation of your water quality. If the water quality exceeds the target levels provided in this table, to prevent build-up of sediment and minerals in the interior of your heater, you must pre-treat or condition the incoming water supply with a filter and/or softener system.

Description	pH	TDS (Total Dissolved Solids)	Total Hardness	Aluminum	Chlorides	Copper	Iron	Manganese	Zinc
Maximum Levels	6.5 to 8.5	Up to 500 mg/L	Up to 200 mg/L	Up to 0.2 mg/L	Up to 250 mg/L	Up to 1.0 mg/L	Up to 0.3 mg/L	Up to 0.05 mg/L	Up to 5 mg/L

SPECIFICATIONS

Name		Gas-fired tankless water heater	
Model		EZ ULTRA	
Type		NG or LPG	
Gas type		Natural Gas or LPG	
Category		I2H	
Rated gas pressure		LPG (0.46) (11"wc)/NG (0.29) (8"wc)	
Nominal heat input (temperature rise 25°C) Q_n		kW	25 (85,350 btu)
Nominal useful output P_n		kW	22 (75,180 btu)
		G/min	4.2
Application water pressure		psi	35 ~ 100 PSI
Min. start water pressure		psi	35
Electricity power supply		V, Hz	115V ~ 60Hz
Maximal input power		W	48
Over current protection fuse		V, A	125V, 2A
Insulation grade		Class I	
Electricity and water protection grade		IP44	
Ignition method		Water controlled auto- pulse ignition	
Temperature control method		Gas proportional valve auto-control	
Temperature display		In Celsius (see conversion chart below)	
Overall dimensions		inches	D 4.5" – W 14" – H 22.5"
Packing dimensions		inches	29.5" x 17.7" x 8.0"
Pipe joint	Gas inlet	G1/2 or G3/4 USA	
	Water inlet	G1/2 USA pipe thread	
	Water outlet	G1/2 USA pipe thread	
	Exhaust duct	Φ100mm (external), Φ60mm (internal)	
WARNING:			
⌘ Read the technical instructions before installing the gas water heater . Installation by trained professionals only.			
⌘ Read the user's instruction manual before lighting the appliance.			



CONTROL PANEL - EZ-ULTRA

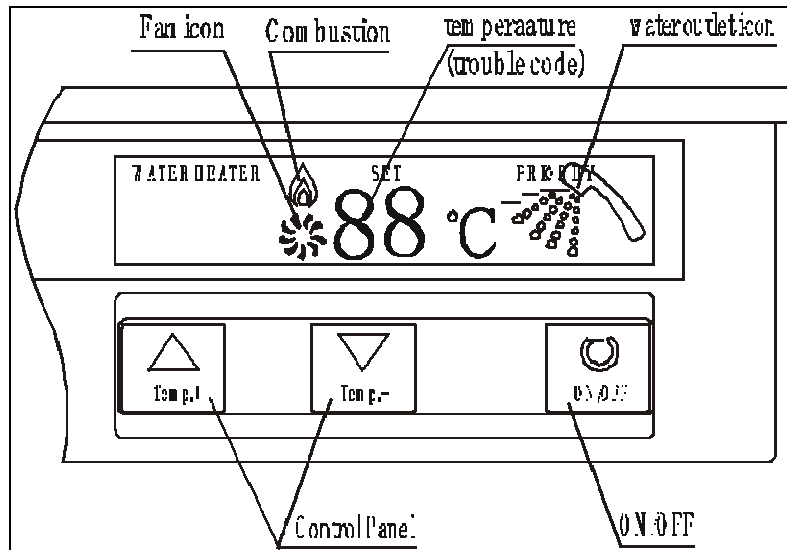

TEMPERATURE CONVERSION CHART FOR USA USERS

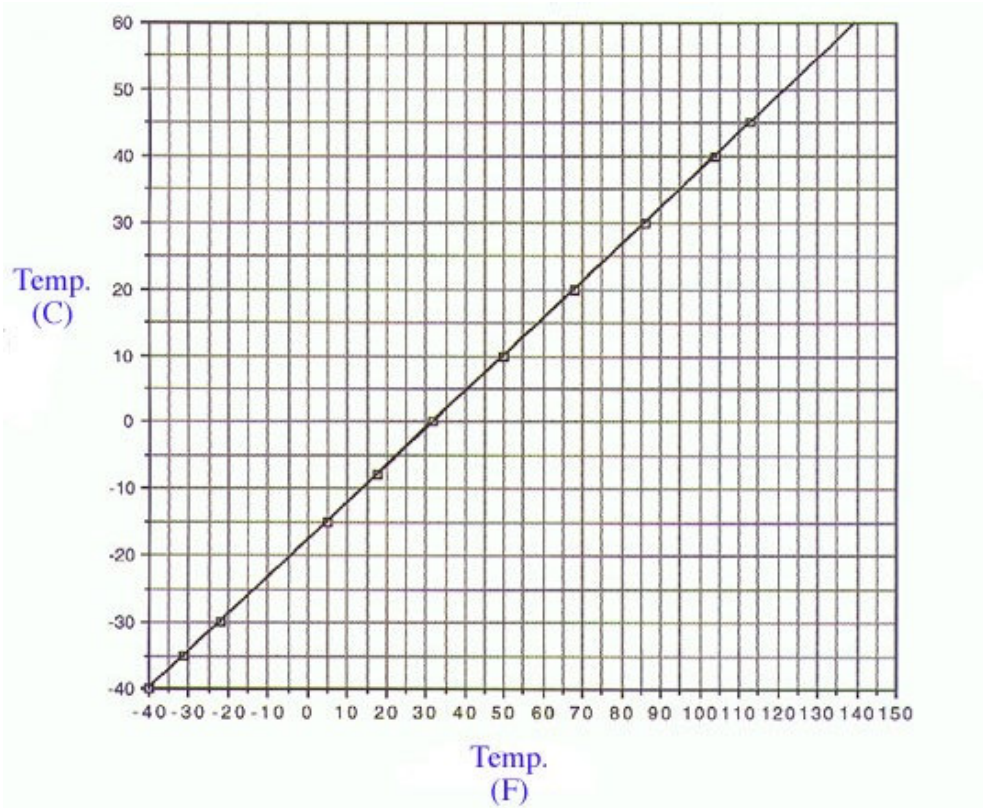

TROUBLE SHOOTING AND COMMON QUESTIONS

Q - *I don't have any hot water when I open the tap!*

A - Make sure there is gas, water and electricity to the Water Heater (the power is turned on and the gas is turned on)

Q - *When I was using the hot water, the water got cold!*

A - If you adjusted the flow from the tap to lessen it, you may have gone below the minimum flow required. The Water Heater requires a minimum flow rate to operate (see specification page for flow rate of your unit). If you mix the water with a tap and attempt to get a temperature well below the temperature being controlled by the unit, it may drop the flow below the desired minimum flow rate. Simply decrease the temperature supplied by the Water Heater at the control panel or increase your total flow.

Q - *White smoke comes out of the exhaust!*

A - During colder weather when the exhaust temperature is hotter than the air, the exhaust fumes condense producing white steam.

Q - *When I open a hot tap. I do not immediately get hot water!*

A - Hot water must travel through your plumbing from the Water Heater to the faucet. The time period for hot water to reach your fixture is determined by the amount of water in your plumbing system between your water heater and the fixture, water pressure, flow rate of fixture in use, etc.

Q - *After I turn off the hot water tap, the fan on the Water Heater continues to run!*

A - The fan is designed to be on for a few seconds after the flow of water stops. This is to ensure constant water temperatures during rapid starting and stopping, as well as exhausting any residual gas flue products from the unit.

CONTROL PANEL FAULT CODES - EZ ULTRA MODEL

Fault Codes

C SUPER THIN GAS WATER HEATER

Fault Codes	Symptoms
E0	Thermostat fault
E1	Ignition failure, unexpectedly flame out
E3	Flue clogged or over high wind pressure
E4	Fan or its circuit fault
E5	Over-high temperature protection
E6	Fault from the temperature sensor of water outlet
E8	Gas-type switch fault

MORE TROUBLE SHOOTING HINTS

Problem	Possible Cause	What To Do
Not enough or no hot water.	Water Shutoff valve is not fully opened.	● Check shutoff valve and open fully.
	Hot water faucet is not fully opened.	● Open hot water faucet completely. (The main burner goes off when incoming water volume is inadequate.)
	Water piping is frozen.	● Allow piping to thaw.
	No electricity or water supply is cut off.	● Check that proper power is being supplied and/or water supply is adequate.
	Unit is not "ON".	● Turn the unit "ON" by the button on the remote control.
	The temperature may be set too low.	● Increase the temperature setting.
	Mixing Valve Malfunctions (if applicable)	● Check and replace if necessary.
	Error code displayed on remote control.	● See instructions for Error Code and if required, contact a dealer for service.
	Not enough water demand.	● Increase water flow.
	Water inlet filter clogged.	● Clean water inlet filter.
	Fixture aerator is clogged.	● Clean aerator.
	Scale buildup in heat exchanger.	● Check for error code. If required, contact a dealer for service.
	Hot and cold water lines reversed.	● Reverse water connections.
Water not hot enough.	The temperature may be set too low.	● Increase the temperature setting.
	The gas valve is not fully opened.	● Check and open the gas valve fully.
	Gas supply pressure is low.	● Call your gas company to verify the gas meter and gas piping size.
	Bleed over in one of the hot water fixtures.	● Call dealer for service.
Water too hot.	Temperature is set too high.	● Decrease the temperature setting.
	Water shutoff valve is not fully opened.	● Check shutoff valve and open fully.
	Small amount of water has been heated.	● Allow more water to flow.
Fan continues to rotate after hot water faucet is closed.	This function is to supply hot water when the hot water faucet is reopened.	● Normal operation. There is no need to call for service.

INTERIOR COMPONENTS OF THE EZ ULTRA MODEL

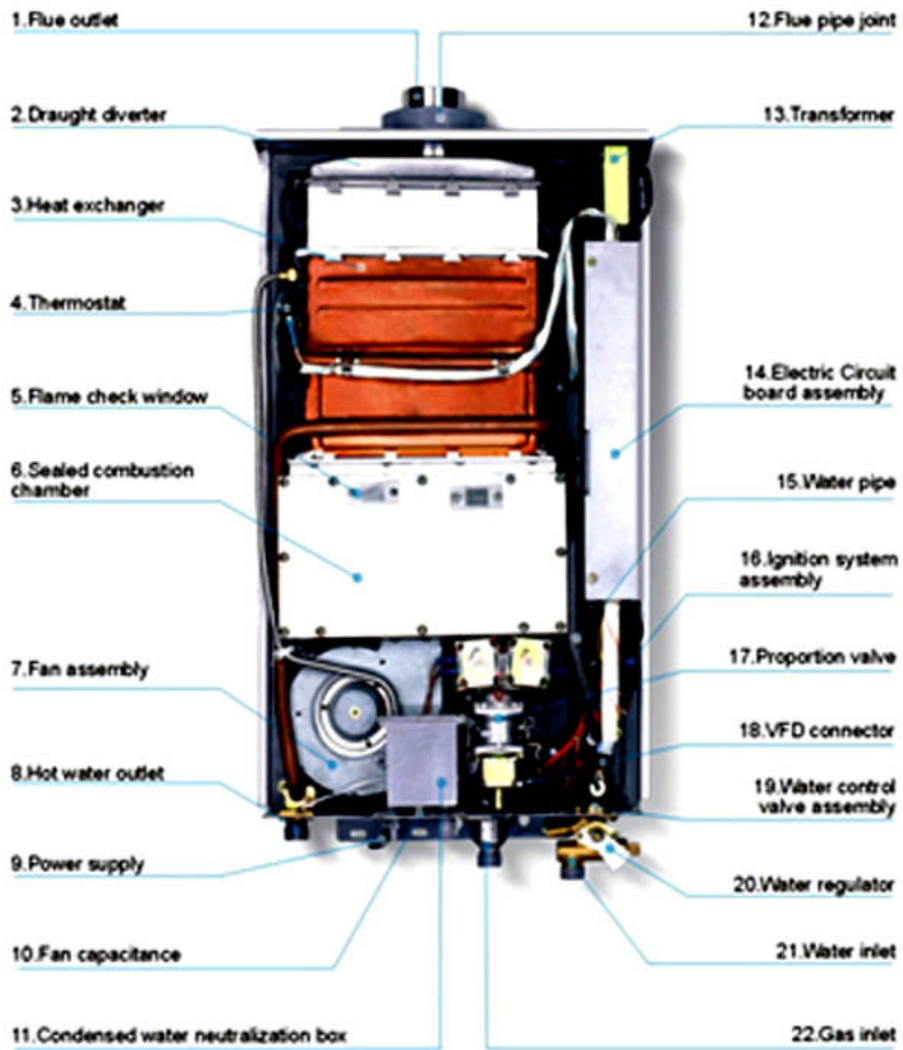

Installer Checklist, to be performed by installer upon installation

Serial Number _____
(8 digit serial number is located on rating plate on right side panel)

Gas Pressure Reading* Static _____ Operating _____

Building Water Pressure _____ Range if on Well system _____

Average Winter Temperature _____

Average Summer Temperature _____

Installing Company _____

Installer name _____

Address _____

Phone _____



NOTE: All specifications are subject to change without notice.

(EZ-Ultra manual - March 2010)